

Timers/Counters

ATmega128/328PB



Timer/Counter Overview

ATmega128



- 2x 8bit Timer/Counter
 - Separate prescaler
 - Compare mode
- 2x 16bit Timer/Counter
 - Separate prescaler
 - Compare mode
 - Capture mode
- Real Time Counter
 - Separate oscillator
- 2x 8bit PWM
- 6x PWM with 2-16bit programmable resolution
- Output compare modulator

Timer/Counter Overview

ATmega328PB



- 2x 8bit Timer/Counter
 - Separate prescaler
 - Compare mode
- 3x 16bit Timer/Counter
 - Separate prescaler
 - Compare mode
 - Capture mode
- Real Time Counter
 - Separate oscillator
- 2x 8bit PWM
- 10x PWM with 2-16bit programmable resolution
- Output compare modulator



Timer/Counter0

- “General Purpose, Single-channel, 8bit T/C”
 - Single channel counter
 - Clear Timer on Compare Match (“auto reload”)
 - Glitch-free, Phase Correct PWM
 - Frequency Generator
 - 10bit Clock Prescaler
 - Overflow Interrupt Source
 - Compare Match Interrupt Source
 - Allows External Clocking using 32kHz Crystal

Timer/Counter0 Block Diagram

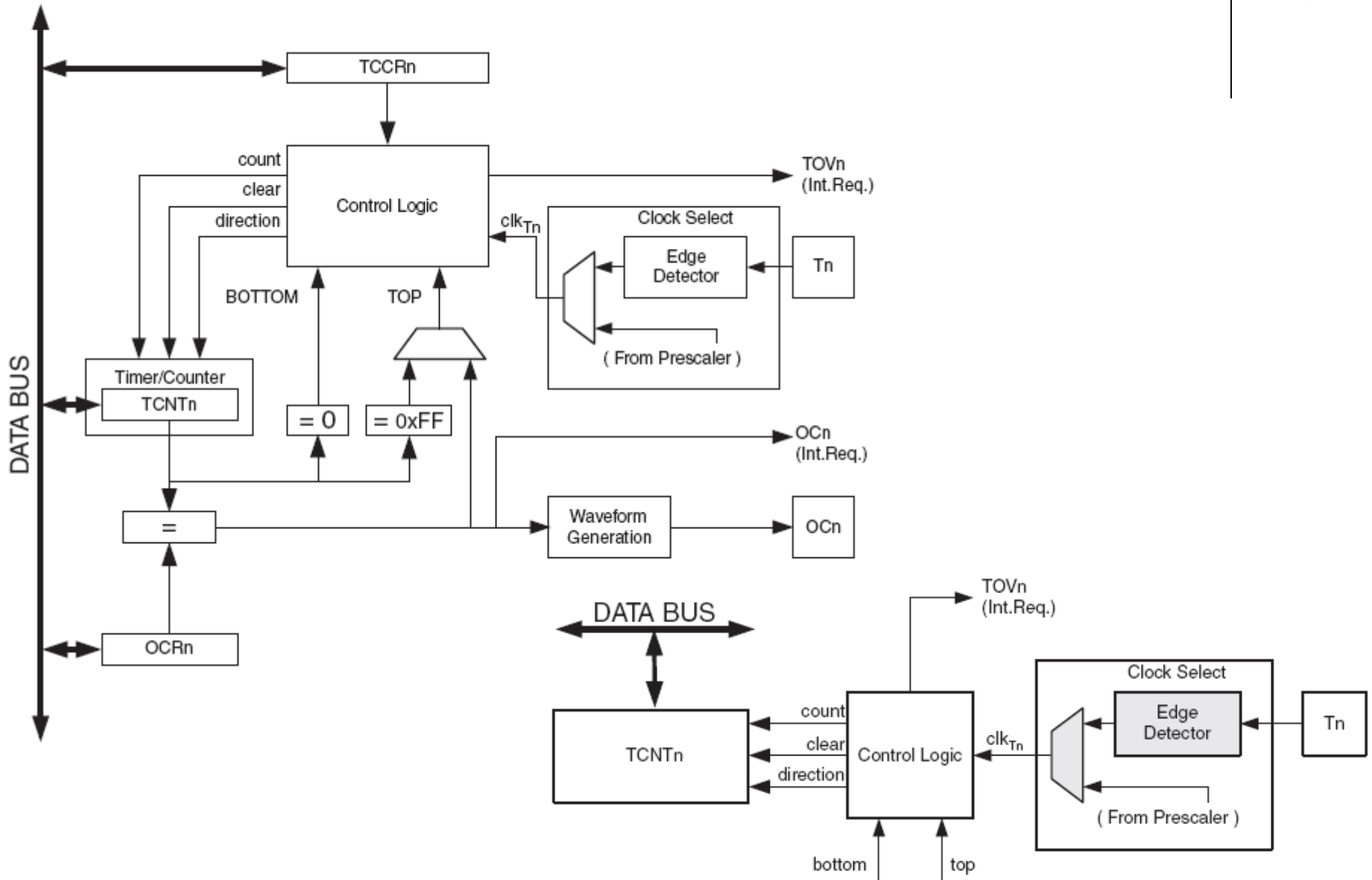

Timer/Counter1,3 Block Diagram

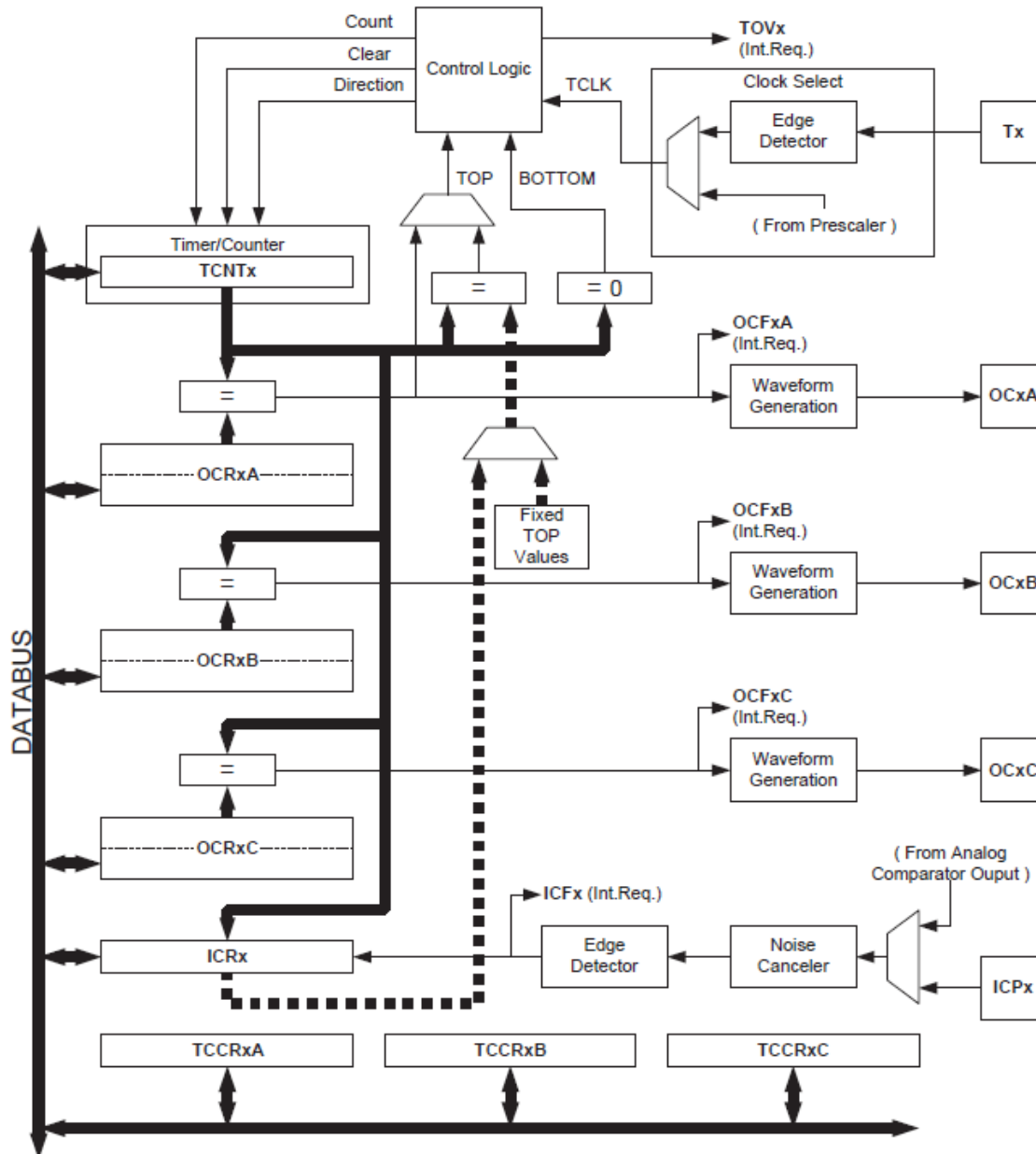

Counter Unit

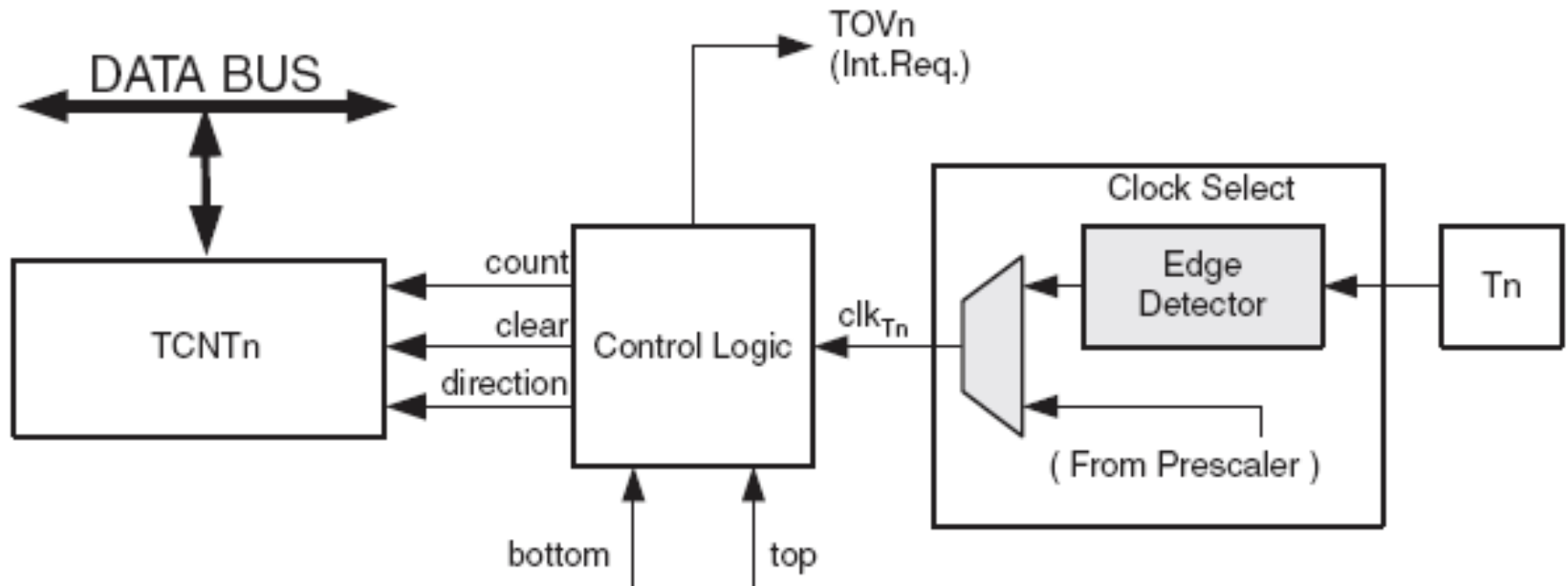



Compare Match Output Unit

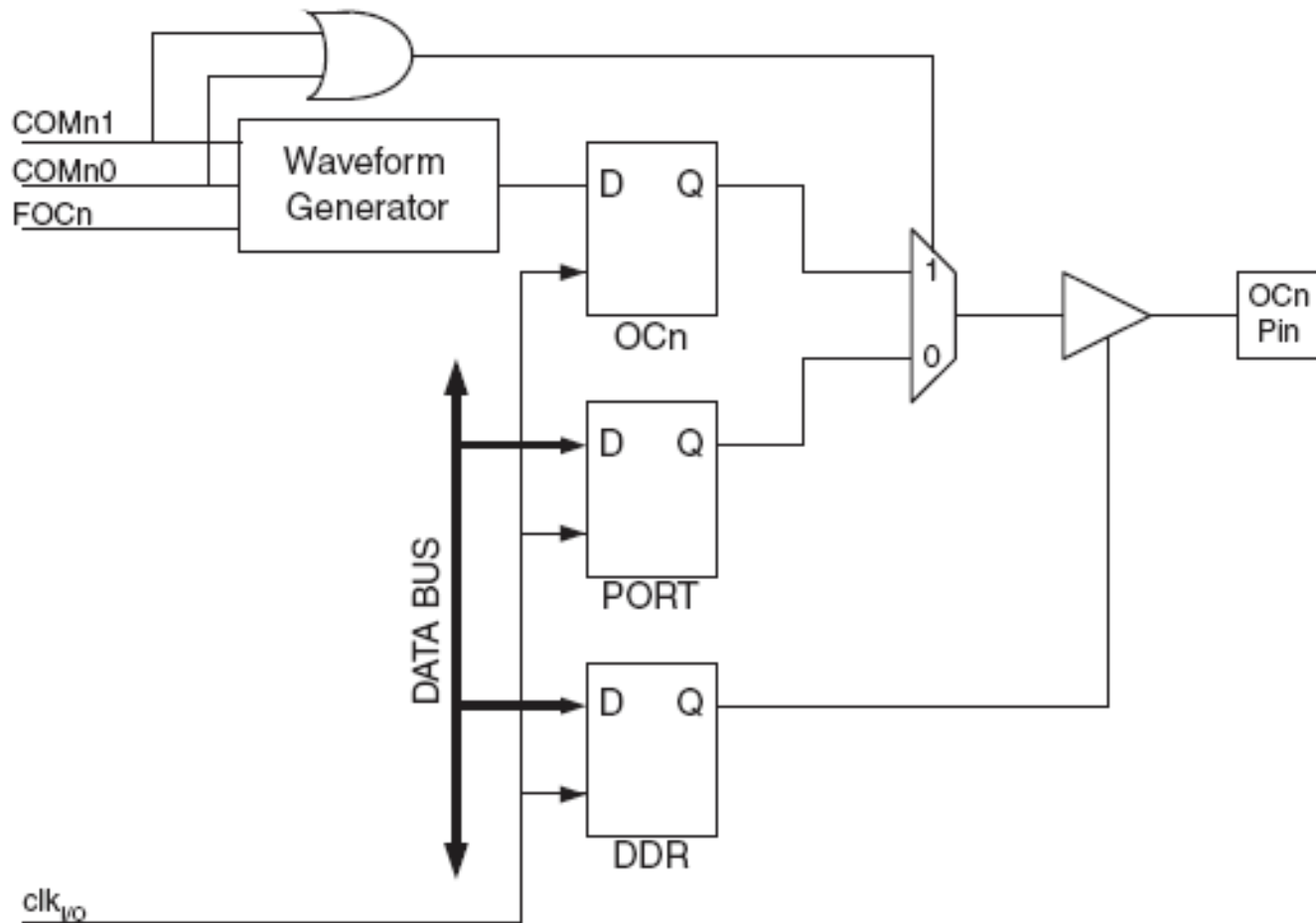



Timer/Counter0 modes

- Normal mode
 - Runs continuously all around, sets TOV0 on overflow
- Clear Timer on Compare Match (CTC) mode
 - Resets when reaches OCR0
- Fast PWM Mode
 - Single-slope operation, 2x fast than phase correct
 - May be inverted
- Phase Correct PWM Mode
 - Dual-slope operation (BOTTOM to MAX and back)
 - May be inverted



CTC mode

- TCNT cleared when it reaches OCR

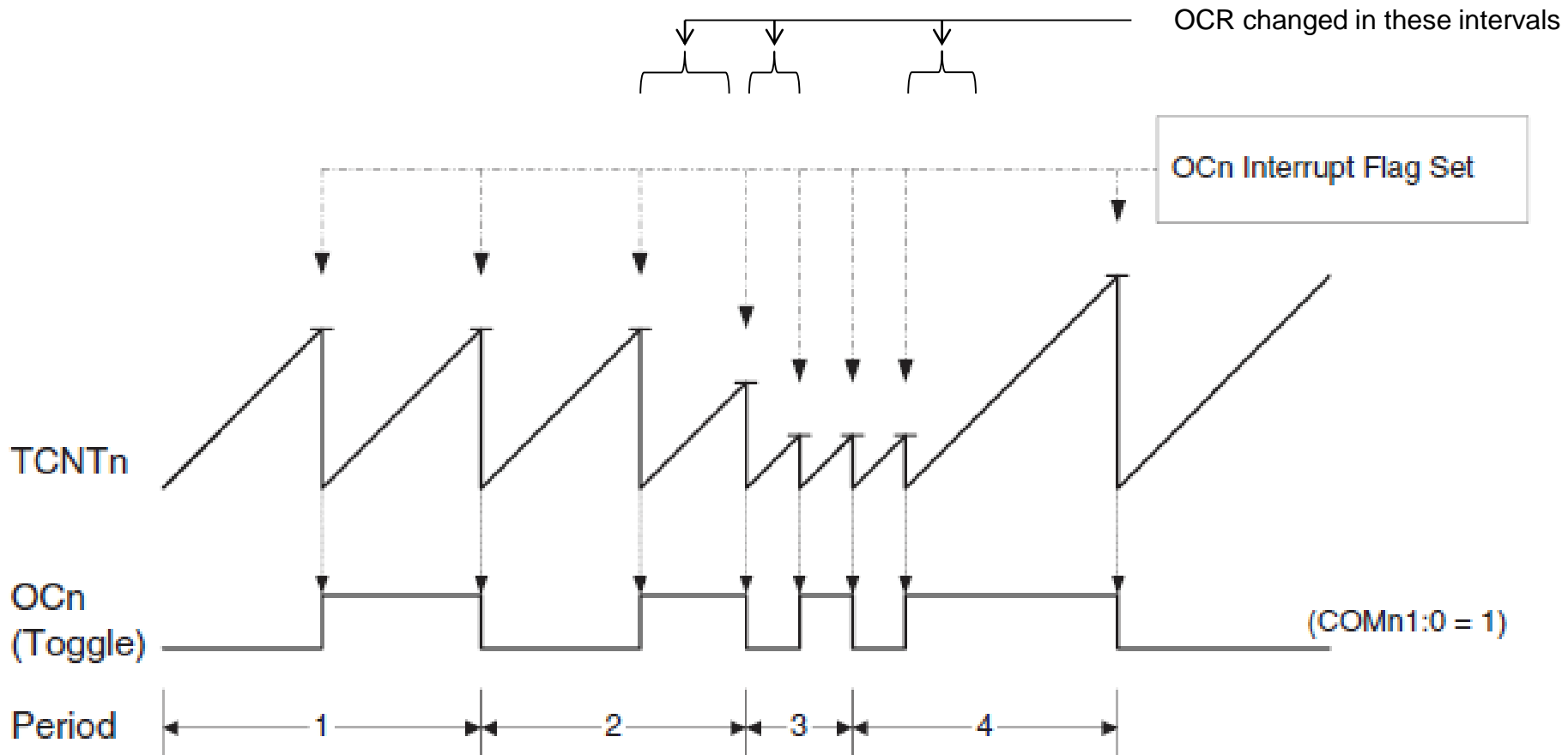



Fast PWM Mode

- single-slope BOTTOM to MAX

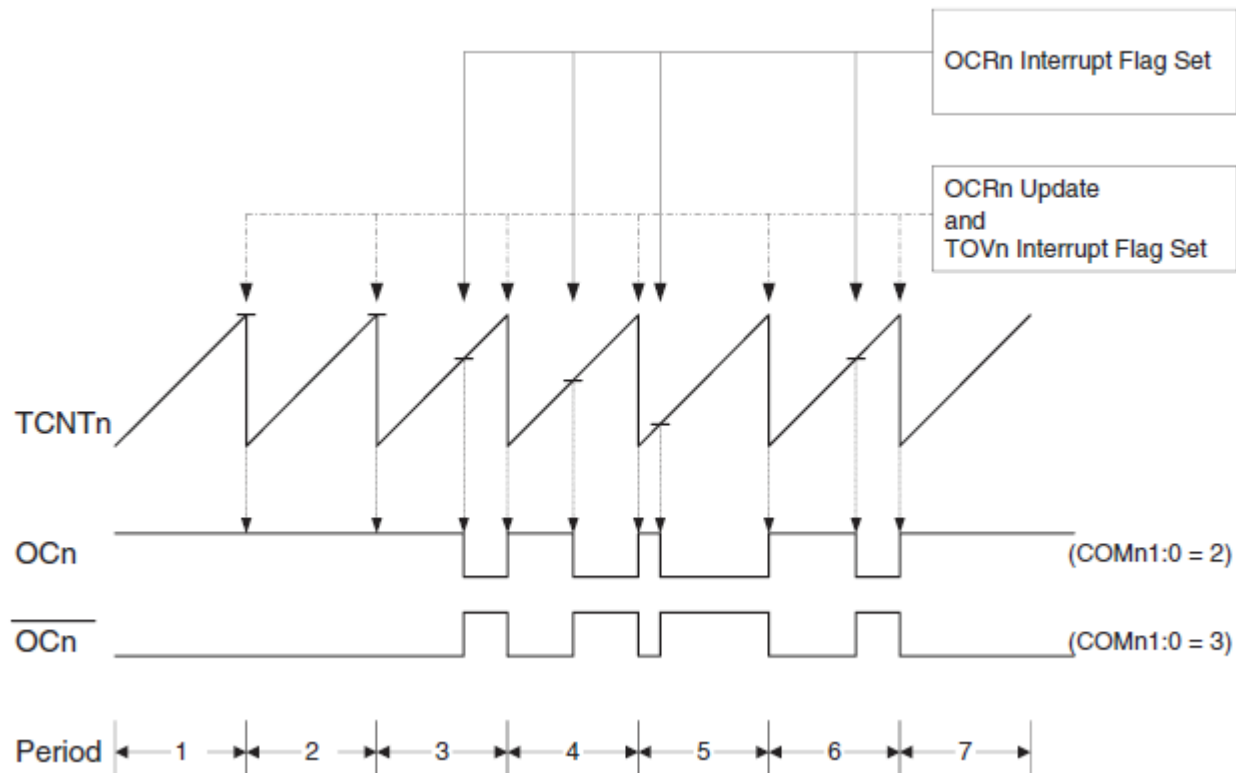



Phase Correct PWM Mode

- dual-slope BOTTOM-MAX-BOTTOM

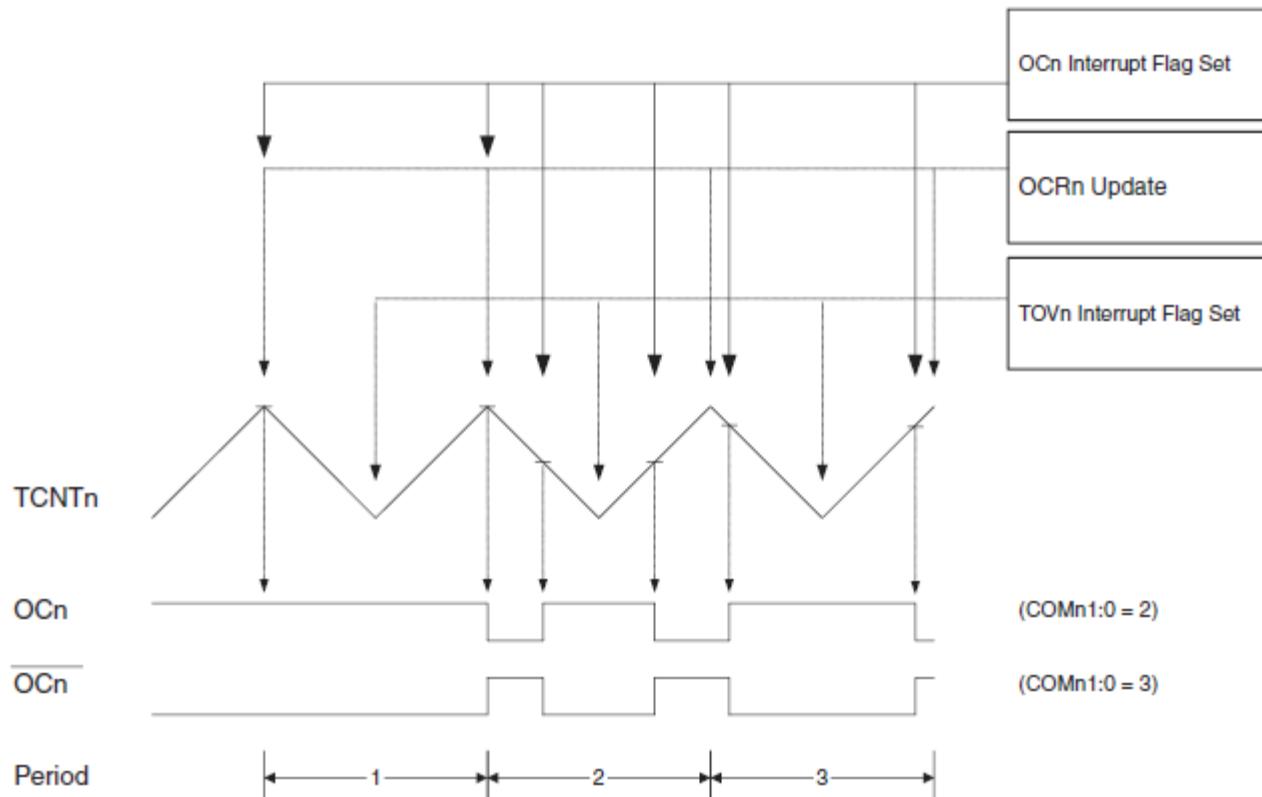

Timer/Counter0 Registers



TCCR0	7	6	5	4	3	2	1	0
	FOC0	WGM00	COM01	COM00	WGM01	CS02	CS01	CS00
	W	R/W	R/W	R/W	R/W	R/W	R/W	R/W
	0	0	0	0	0	0	0	0

FOC0 Force Output Compare

Only for non-PWM mode

WGM01:0 Waveform Generation Mode

T/C0 Mode	TOP	OCR0 update	TOV0 set
00 normal	0xFF	imm	MAX
01 Phase PWM	0xFF	TOP	BOTTOM
10 CTC	OCR0	imm	MAX
11 Fast PWM	0xFF	BOTTOM	MAX

Timer/Counter0 Registers



TCCR0	7	6	5	4	3	2	1	0
	FOC0	WGM00	COM01	COM00	WGM01	CS02	CS01	CS00
	W	R/W	R/W	R/W	R/W	R/W	R/W	R/W
	0	0	0	0	0	0	0	0

COM01:0 Compare Match Output Mode

Defines OC0 behaviour based on the mode

If used, must be set as output

CS02:0 Clock Select

Sets prescaler (for internal clock only)

000 No clock (T/C stopped)

001-111 prescaler (1, 8, 32, 64, 128, 256, 1024)

this is different for counters 1-3!

Timer/Counter0 Registers



ASSR	7	6	5	4	3	2	1	0
	-	-	-	-	AS0	TCN0UB	OCR0UB	TCR0UB
	R	R	R	R	R/W	R	R	R
	0	0	0	0	0	0	0	0

AS0 Asynchronous Timer/Counter0

1 ... clocked by crystal oscillator connected to TOSC1

TCN0UB Timer/Counter0 Update Busy

0 ... TCNT0 is ready to be updated

OCR0UB Output Compare Register0 Update Busy

0 ... OCR0 is ready to be updated

TCR0UB Control Register0 Update Busy

0 ... TCCR0 is ready to be updated

Timer/Counter0 Registers

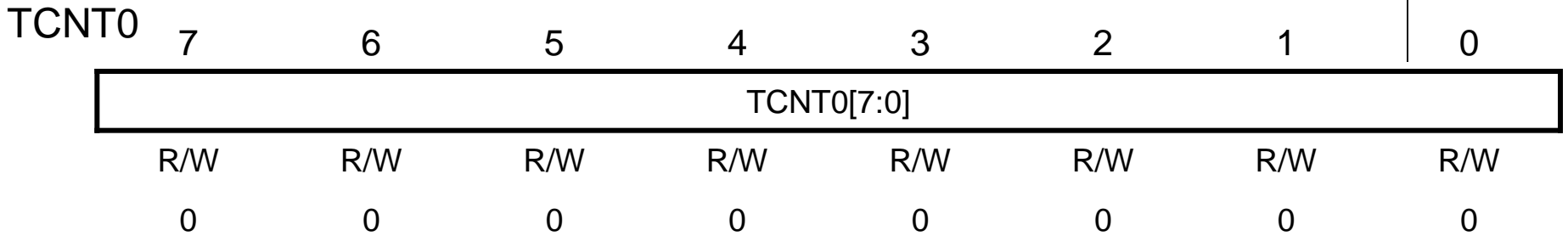

TCNT0[7:0] 8-bit counter

Timer/Counter0 Registers

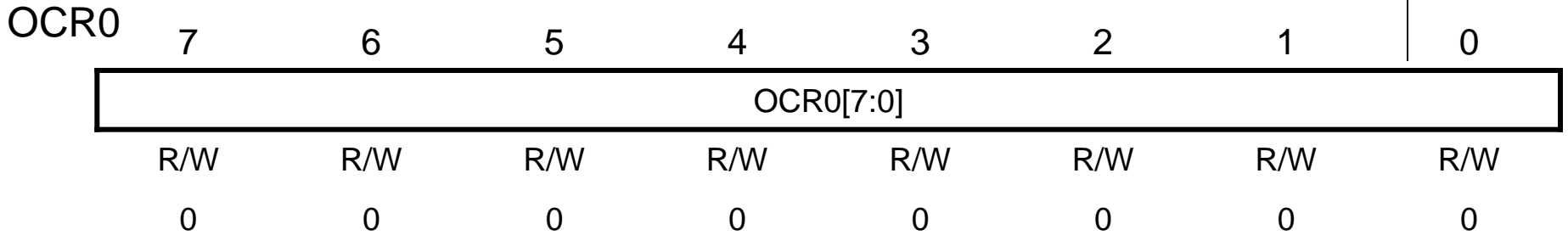

OCR0[7:0] Output Compare Register

Timer/Counter0 Registers



TIMSK	7	6	5	4	3	2	1	0
	OCIE2	TOIE2	TICIE1	OCIE1A	OCIE1B	TOIE1	OCIE0	TOIE0
	R/W	R/W	R/W	R/W	R/W	R/W	R/W	R/W
	0	0	0	0	0	0	0	0

OCIE0: Output Compare Match Interrupt Enable

TOIE0: Overflow Interrupt Enable

Timer/Counter0 Registers



TIFR	7	6	5	4	3	2	1	0
	OCF2	TOV2	ICF1	OCF1A	OCF1B	TOV1	OCF0	TOV0
	R/W	R/W	R/W	R/W	R/W	R/W	R/W	R/W
	0	0	0	0	0	0	0	0

OCF0: Output Compare Flag

TOF0: Overflow Flag